

# RAILING INFILL PANELS

AVAILABLE STANDARD MESHES

- 10ga. 1 1/2" diamond mesh
- 6ga. 2" diamond mesh
- 11ga. 1" square mesh
- 10ga. 1 1/2" square mesh
- 8ga. 2" square mesh
- 1/4" dia. 2" square mesh
- 1/8" dia. 2" square mesh

Note: Other custom meshes in various gauges and patterns available.

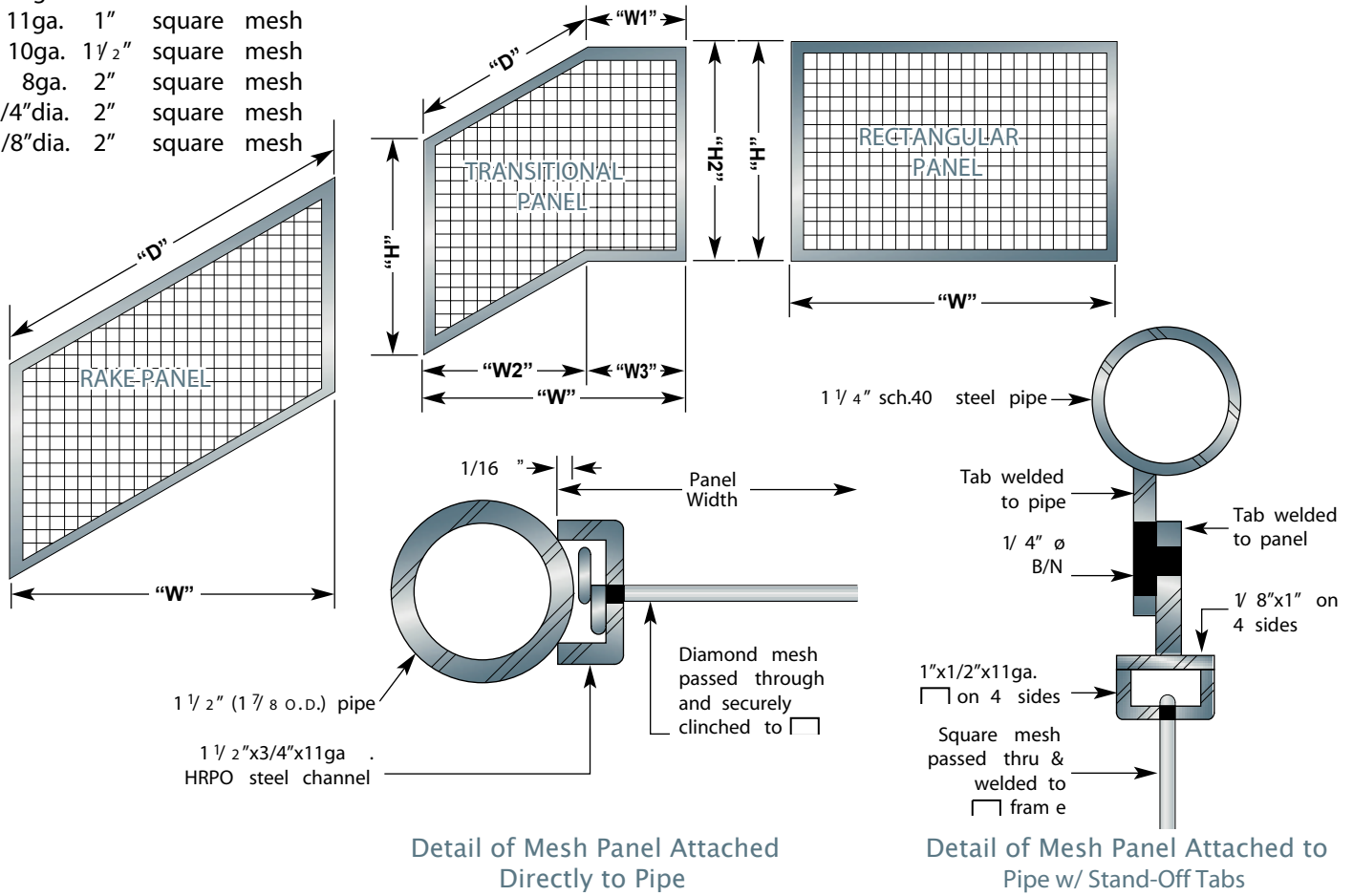

Detail of Mesh Panel Attached Directly to Pipe

Detail of Mesh Panel Attached to Pipe w/ Stand-Off Tabs

# FRAMING OPTIONS

Illustrations shown 1/2 scale

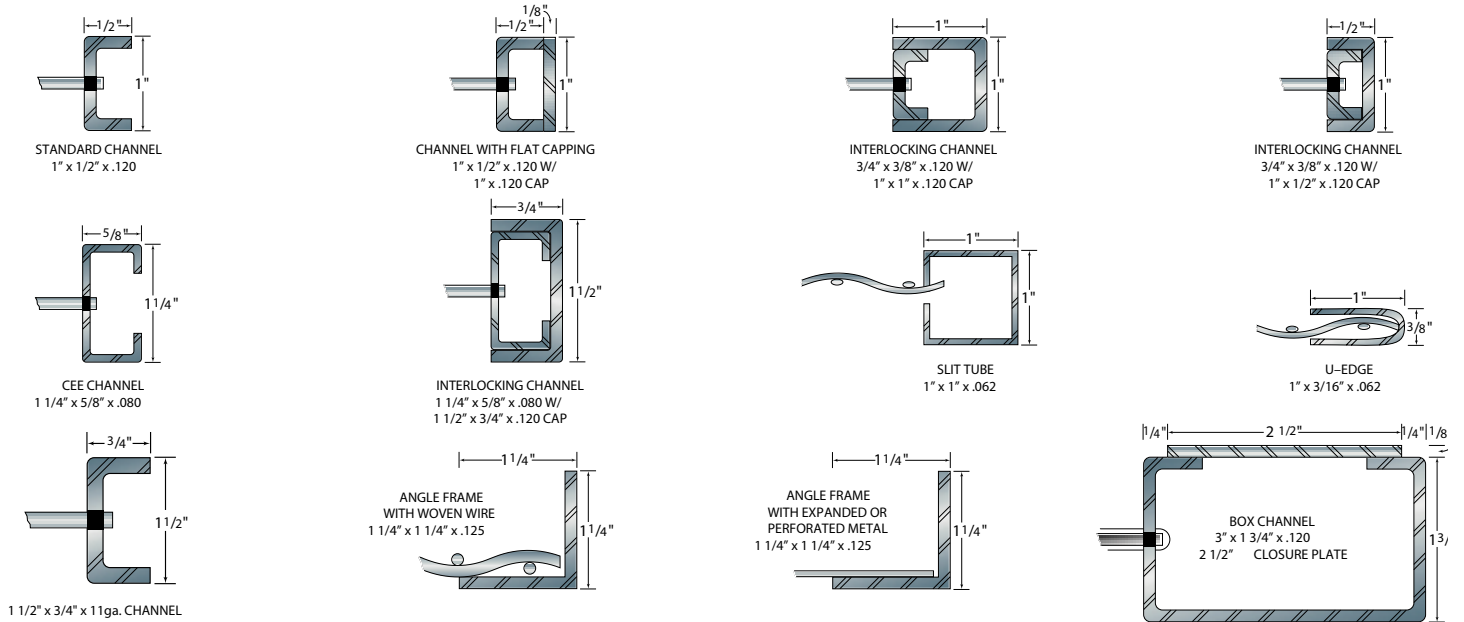

PHONE: (732) 661-2001



FAX: (732) 661-2003

